

BOONDALL COMMUNITY



Kindergarten

2022

Name _____

Locker _____

**PLEASE RETAIN THIS BOOKLET AS IT CONTAINS
IMPORTANT INFORMATION THAT YOU REQUIRE WHILE
YOUR CHILD IS ENROLLED AT THIS CENTRE.**



Lady Gowrie^{QLD}
Community
Kindergartens

Contents

TEACHERS	1
ASSISTANTS.....	1
COMMENCEMENT DAY	1
OPEN DAYS	1
2022 TERM DATES.....	1
BOONDALL KINDERGARTEN ASSOCIATION INCORPORATED	2
ACKNOWLEDGEMENT OF COUNTRY	2
WELCOME TO OUR CENTRE.....	2
CENTRE HISTORY	2
NATIONAL QUALITY FRAMEWORK	2
AFFILIATION	3
STAFF.....	3
FINANCE ADMINISTRATOR.....	3
OFFICE ADMINISTRATOR	3
STAFF ROLES.....	4
STAFF PROFESSIONAL DEVELOPMENT	4
FIRST AID.....	4
SUITABILITY / BLUE CARD	4
GOALS AND AIMS OF A KINDERGARTEN EDUCATION.....	5
OPERATION	5
ARRIVAL/DEPARTURE PROCEDURE.....	6
EDUCATIONAL CURRICULUM.....	7
PHILOSOPHY STATEMENT FOR BOONDALL KINDERGARTEN	7
OUR CENTRES GOALS.....	8
INFORMATION FOR PARENTS AND CARERS	9
CHILD PROTECTION LEGISLATION INFORMATION	9
CODE of CONDUCT.....	10
BOONDALL KINDERGARTEN PARENTAL CODE of CONDUCT	10
THE FIRST FEW DAYS.....	11
How will I know when to say good-bye?.....	11
What should I know about picking up my child at the end of the day?	12
Is your child ready? What can I do to prepare my child for Kindy?.....	12
REST TIME	12
BIRTHDAYS.....	12
TOYS	12
FOOD AND NUTRITION.....	13
REQUIREMENTS FOR KINDERGARTEN	13
CLOTHING	14
LITTERLESS LUNCHES	14
INCLUSION POLICY	14
SICK CHILDREN	14
MEDICATION (AS PER Lady Gowrie Qld POLICY STATEMENT).....	15
SUN PROTECTION	15
ENVIRONMENTAL SUSTAINABILITY	16
WEARING SHOES	16
INJURIES.....	16
IMMUNISATION IS VITAL	16

FIRE DRILLS, EMERGENCY & EVACUATION PROCEDURES.....	17
HEALTH, HYGIENE & SAFETY.....	17
INSURANCE.....	17
SMOKING.....	17
STUDENT PLACEMENT/WORK EXPERIENCE.....	17
FEES.....	18
FEES STRUCTURE.....	18
FEE DUE DATE & PAYMENT OPTIONS.....	19
FEES IN ARREARS/ LATE FEE.....	19
QKFS KINDY PLUS SUPPORT.....	19
ROSTER BOND.....	20
MEMBERSHIP.....	20
FAMILY INVOLVEMENT / VOLUNTEERS.....	20
PARENT RESPONSIBILITIES.....	20
PARENT/TEACHER COMMUNICATION.....	21
WAITING LIST.....	21
PARENT LENDING LIBRARY.....	21
ENROLMENT/ FEE PAYMENT AGREEMENT.....	22
MANAGEMENT COMMITTEE.....	25
JOB DESCRIPTIONS.....	25
Executive Positions.....	25
President.....	25
Secretary (often a shared position).....	25
Vice President/Treasurer.....	26
Non-Executive Positions.....	26
Workplace Health & Safety Officer.....	26
Working Bee Officer.....	26
Marketing Officer.....	26
Grants Application Officer (a shared position).....	26
Technology Officer.....	26
Social Committee / Einbunpin Sub-Committee.....	26
COMMUNICABLE CHILDHOOD DISEASES.....	27
Chicken Pox.....	27
Measles.....	27
German Measles (Rubella).....	27
Mumps.....	27
Streptococcal Infections.....	27
COMMUNICABLE CHILDHOOD DISEASES (CONT'D).....	28
Whooping Cough.....	28
Ringworm.....	28
Scabies.....	28
Head Lice.....	28
Conjunctivitis.....	28
School Sores.....	28

TEACHERS

Kerri Pahor (Group 1)
Marnie Poulsen (Group 2)

ASSISTANTS

Merody Buglar (Group 1)
Nikki Murray (Group 2)

COMMENCEMENT DAY

Group 1 Commencement Schedule

Week 1	Monday 24 th Jan	8:42am to 12:50pm
	Tuesday 25 th Jan	8:42am to 12:50pm
Week 2	Monday 31 st Jan	8:42am to 2:50pm
	Tuesday 1 st Feb	8:42am to 2:50pm

Group 2 Commencement Schedule

Week 1	Thursday 27 th Jan	8:42am to 12:50pm
	Friday 28 th Jan	8:42am to 12:50pm
Week 2	Wednesday 2 nd Feb	8:42am to 2:50pm
	Thursday 3 rd Feb	8:42am to 2:50pm
	Friday 4 th Feb	8:42am to 2:50pm

**Please send a hat, some morning tea and lunch.
Sheets will be needed once your child attends a full day session.**

OPEN DAYS

Beginning of Week - Group 1 Thursday 20th January 2021 (9.00 – 10.30am)

End of Week - Group 2 Wednesday 19th January 2021 (9.00 – 10.30am)

****Please bring a hat, some morning tea and water bottle****

2022 TERM DATES

Term One Monday 24th January – Friday 1st April
Term Two Tuesday 19th April – Friday 24th June
Term Three Monday 11th July – Friday 16th September
Term Four Tuesday 4th October – Friday 9th December

31 CARLYLE ROAD, BOONDALL Qld 4034
TELEPHONE (07) 3265 5439
EMAIL admin@boondallkindy.com.au





BOONDALL KINDERGARTEN ASSOCIATION INCORPORATED

ACKNOWLEDGEMENT OF COUNTRY

We acknowledge the traditional custodians of this land and offer our respects to the aboriginal elders of past and present. We remember that our kindergarten is built on traditional aboriginal land, and support knowledge recognition and respect for Aboriginal people and culture.

WELCOME TO OUR CENTRE

Welcome to Boondall Kindergarten and congratulations on choosing an affiliated Lady Gowrie Qld Community Kindergarten. Your family is now part of a long tradition in quality early childhood education and care.

To build genuine partnerships we believe it is important that staff value children and their families. Staff acknowledge the importance of families and communities at the service and appreciate the ongoing support of families who give their time and skills generously. Boondall Kindergarten aims to engage children and families in a sense of community, cooperation and collaboration. We encourage you to become actively involved in this centre. Your involvement will enrich your child's learning experiences and promote positive self-esteem.

CENTRE HISTORY

The Kindergarten began in the old scout hall in 1967. The Boondall Progress Association owned the land and hall and rented the premises at no cost. On 10 September 1969 a motion was passed unanimously to transfer the property to the Boondall Kindergarten Association (B.K.A.) for \$1.00. On 9 July 1970 the B.K.A. became incorporated. On 10 September 1970 consent was given to erect the building which is now the Kindergarten. It was officially opened on the 25 September 1971 by Mr. Jack Melloy M.L.A. Mrs. Marie Buckler was the first teacher at the centre. In 1993 the Kindergarten became licensed under the new guidelines controlled by the Department of Family Services.

NATIONAL QUALITY FRAMEWORK

The early childhood education and care sector in Australia now operates under the National Quality Framework (NQF). Boondall Kindergarten delivers a Queensland Government approved kindergarten program. We adhere to the National Quality Standards, and have implemented a Quality Improvement Plan, which is an ongoing improvement document under continual review. For more information, speak to your child's teacher. The Australian Children's Education and Care Quality Authority oversees the NQF. For more information, visit <http://acecqa.gov.au/> or phone 1300 422 327.

AFFILIATION

The Boondall Community Kindergarten is affiliated with Lady Gowrie Qld Community Kindergartens. As an affiliated centre we adhere to the Department of Education's recognised play-based curriculum and the Queensland Kindergarten Learning Guidelines. This allows children to problem solve, discover and learn how to be independent thinkers.

The affiliation provides firm guidelines for the:

- smooth running of the Centre;
- ensures that the Kindergarten provides education of a high standard;
- receives the appropriate Government subsidy of approximately \$2,800 per enrolled child. This is roughly 50% of all running costs of the Kindergarten. Fees are calculated to cover the balance of salaries and running costs.

Boondall Kindergarten is approved and regulated by the Office for Early Childhood Education and Care under the Education and Care Services Act 2013. The Centre must meet the requirements, experiences and programs, numbers of staff members and children, and staff members qualifications according to the legislation.

The Gowrie (Qld) Inc
Ph: 3252 2667 Email: info@ladygowrie.com.au
Web: www.gowrieqld.com.au



STAFF

TEACHING STAFF

Mrs Kerri Pahor (Dip Tch E.C.) is the Co-Director of the Kindergarten and teacher at the beginning of the week (Group 1).

Mrs Marnie Poulsen (Dip Tch Primary/E.C.) is the Co-Director of the Kindergarten and teacher at the end of the week (Group 2).

Mrs Merody Buglar (Cert E.C.) is the Assistant Teacher for Group 1

Mrs Nikki Murray (Ass Dip Education/Childcare) is the Assistant Teacher for Group 2

A high teacher / child ratio allows teachers the individual time to spend with your child. Boondall Kindergarten has 2 teaching staff for every 22 children.

FINANCE ADMINISTRATOR

Mrs Jodi Browning is the financial administrator.

OFFICE ADMINISTRATOR

Mrs Emma Jager is the administrative assistant.

STAFF ROLES

Nominated Supervisors (Directors/Teachers)

The Director works with staff, committee, parents and children to carry out the policies of the centre. The Director attends committee meetings, reports to the management committee and keeps records up to date. The Director plans for, and maintains high standards in the administration of the centre. As well, the Director keeps a written curriculum and child developmental records for the children of their groups. The Director ensures the children's supervision, health and safety. They promote the centre within the community and participate in professional development.

Assistant

The assistant helps the teacher in the preparation and supervision of activities. They provide another role model for the children. They are flexible in following the changing interests and needs of the children. They offer their own talents and skills to enrich the program. They help to ensure children's health and safety. They also fulfill housekeeping duties. They promote the centre within the community.

STAFF PROFESSIONAL DEVELOPMENT

All staff regularly attends seminars and conferences, allowing them to keep up to date with current educational trends. Teaching staff are to participate in 20 hours of professional development each year.

FIRST AID

All staff in contact with children hold a current Senior First Aid Certificate and current CPR, anaphylaxis, asthma management & training certificates as required by the Education & Care Services Act 2013.

SUITABILITY / BLUE CARD

The Education & Services Act 2013 includes a requirement for all staff and volunteers working with children to hold a current suitability/exemption blue card. The blue card is issued by the Blue Card Services to an individual after a criminal history check is conducted and the staff member, having no criminal record, is therefore deemed to be suitable for working with children.

We encourage all parents and/or guardians to apply for a blue card as a helpful resource to use as your child(ren) begins their journey through the education process.

GOALS AND AIMS OF A KINDERGARTEN EDUCATION

1. The Centre is a community owned, non-profit organisation which aims to provide a learning environment and experiences that will enhance and give meaning to the child's relationships with the world and its people.
2. The teacher's role is to enhance learning through planning and interactions with children, while encouraging, extending and valuing children's spontaneous learning through the medium of Play.
3. Our aim is to:
 - understand children;
 - build partnerships;
 - establish flexible learning environments and;
 - support the children's play.

The curriculums we follow in the Boondall Kindergarten program are known as the Queensland Kindergarten Learning Guidelines and "The Early Years Learning Framework". It invites children and adults to take part in a journey – a journey that requires a commitment to potentials, possibilities, aspirations and inspirations.

Queensland Kindergarten Learning Guidelines focuses on:

- Identity;
- Connectedness;
- Wellbeing
- Active learning; and
- Communicating

The ELYF focus is on the areas of:

- Belonging
- Being
- Becoming

We believe that children are competent and capable learners.

Parents and guardians are invited to discuss the activities and experiences provided as part of the learning programs and the goals to be achieved throughout our programs. Please see your teacher for more information about your child's development and our philosophy of learning that underpins our programs.

OPERATION

The Kindergarten operates as a single unit centre catering for Kindy (3.5 years – school age) aged children. The children attend 5 days per fortnight (Monday, Tuesday and alternating Wednesday) or (Thursday, Friday and alternating Wednesday). The hours are 8.42 am to 2.50 pm. We are aware that some families may have pick up at schools. We understand that this may require an early pick up of your kindy child to ensure you have adequate time to arrive at school. We will endeavour to have children ready for pick up between 2.15 pm – 2.45 pm.

***** ALL CHILDREN MUST BE PICKED UP BY 2.50 PM TO COMPLY WITH CURRENT REGULATIONS.*****

ARRIVAL/DEPARTURE PROCEDURE

Each child must be brought to the centre and collected by a parent or a responsible, parent nominated adult, eighteen years or over. Parking is along Carlyle Rd. and Queenstown St. Please be considerate of our neighbours and avoid parking across driveways. Yellow lines indicate no parking areas.

ARRIVAL

On arrival, parents/carers must fill out their arrival time, printing their name and signing where indicated. **Please ensure you apply sunscreen to your child on arrival and tick the box provided to indicate this.** Sunscreen is provided if you do not bring your own. **Please also ensure that your child has cleaned their hands upon arrival either by using the hand gel provided or by washing their hands in the bathroom when entering the room.** Indicate this by noting the time in the section provided.

CHILD'S NAME	Time	NAME (please print)	SIGNATURE	Sun Screen	Hands	Messages
Kate Smith	IN 8.42	Mary Smith			IN 8.42	
	OUT				OUT	

Encourage your child to unpack their bag and put their lunch in the fridge and sheets in the sheet basket. They will need to bring their drink bottle in when the door is open. Drink bottles will go on the trolley on the patio. Shoes are removed and go on the shoe rack.

DEPARTURE

At the end of the day, please fill in the time sheet indicating the time you are collecting your child and sign. Check the messages section for any notes from the teacher. You may also add messages to this section.

CHILD'S NAME	Time	NAME (please print)	SIGNATURE	Sun Screen	Hands	Messages
Kate Smith	IN				IN	
	OUT 2.50	Mary Smith			OUT	

Please notify your child’s teacher of any variances to pick –up time that you may need. **You must complete a ‘Temporary Authorisation to Collect’ form to request another person to collect your child.** We may request identification (Driver’s License) if that person is unknown to us.

We will never release your child to someone who is not properly authorised by you.

Staff require time to prepare and tidy up at either end of the daily program time. To enable this, we seek your co-operation in keeping to the session times.

EDUCATIONAL CURRICULUM

A flexible, child-centred curriculum which follows the Queensland Kindergarten Learning Guidelines and the Early Years Learning Framework is implemented for each group. The day consists of free selection of resources and focuses on play in both the indoor and outdoor learning environment. Group sessions occur at varying intervals during the day, emphasising language development and experience with stories and music and movement. We recognise that every child is an individual. We aim to enable each child to develop at his/her own pace throughout the year. Your child's curiosity, enthusiasm and love of learning will continually be encouraged by staff. As teachers and children engage in inquiry together, children are learning to observe, ask questions, reflect on their actions, and engage in meaningful and self-directed activity. To make sure we nurture and develop our future generations of thinkers, play is an essential component of a quality early childhood educational experience.

PHILOSOPHY STATEMENT FOR BOONDALL KINDERGARTEN

The convention on the rights of a Child forms the basis of our teaching philosophy. We recognize that each child has the right to education. Our Centre believes that the kindergarten year is a fundamental time for establishing foundations for a love of learning that will last a lifetime.

We believe that children of all ages are competent and capable. Childhood is a time to be treasured; children are joyous, spontaneous, curious and creative. We aim to encourage each child's self-confidence and believe that by promoting a positive, self-image the children in our care will develop to their full potential. We understand and respect that each child is unique and provide an inclusive environment.

We recognize and acknowledge the influence that family and community have on each child. Families are the immediate and continuing source of security, identity, stability and learning for each child; they are their first and most important educators. Respectful communication and engaging in shared decision making with children, educators, families and community provides the best learning outcomes for students in our care.

We believe that children learn best by providing an environment where they feel safe, secure, accepted, and welcomed. Our role is to nurture each child to develop a sense of belonging and understand the importance of being an individual, a member of the Kindergarten group and wider community. Our role is to provide a vibrant and flexible environment that is responsive to the interests and abilities of each child, promoting autonomy and the love of learning.

We create a program in partnership with children that supports each child, catering to rights of the child and the right to their own culture, religion and language. We believe that respectful learning is child orientated and initiated; our role is to provide a program that caters for all stakeholders. We are able to provide this program by using a classroom management system that align with our philosophy and promote each child as an important part of the educational process.

We have a commitment to a sustainable future, we encourage, and model responsibility in the natural and built environment. Play based learning is the foundation of our program. Through play, we provide opportunities for children to discover, create, improvise and imagine. We aim to support children's learning and extend their knowledge and skills. The children in our Centre enjoy their Kindy experience as they learn many things about the world around them and make many new friends.

We believe that learning is child orientated and initiated; our role is to provide a program that caters for all stakeholders. We acknowledge the traditional custodians of our land, the Turrbul people and respect the land that we play on. Through the implementation of the QKLG and EYLF, we invite children and adults on a learning journey. This journey requires a commitment to potentials and possibilities from all stakeholders.

OUR CENTRES GOALS

- To create an atmosphere of trust, security and comfort
- To provide a safe, clean and sustainable environment
- To provide an enriched and stimulating environment to meet the needs of the whole child.
- To acknowledge the uniqueness and individual worth of each child and their families.
- To provide a program that meets the needs of both the group and individual child.
- To utilise the skills and knowledge of our families and the wider community

Our aim is to;

- Understand children
- Build partnerships
- Establish inspiring and flexible learning environments
- Support the children's play
- Provide positive outcomes for our children

Families

Families, the extended family and the community are the most important and powerful influence on the child because they provide the context for children's growth and development including the development of beliefs, values, knowledge, skills and attitudes.

Therefore, Boondall staff value the knowledge and provocations and questions that families bring and share and, in turn families are asked to value the professional knowledge and experience that staff bring to the learning community and to the family staff relationship.

Boondall Kindergarten Staff believe that...

Staff within our setting value and respect the children, their families and each other and in turn have the right to be valued and respected by the children, families, and members of the community.

In Summary

In early childhood school as well as the wider community, parenting, educating and caring for children is and should be a shared responsibility. As members of this learning community Boondall Kindergarten staff are willing to share this role with families valuing and embracing diversity and upholding the rights of children and of each other and accepting the responsibilities that these relationships require.

INFORMATION FOR PARENTS AND CARERS

Creating safe and supportive service environments for children is everyone's business. Our organisation is committed to providing the highest standard of service to children and ensuring they are kept safe from harm.

Boondall Kindergarten & The Gowrie Qld promotes the protection of all children and encourages a culture of awareness and education throughout the early childhood education and care sector in Queensland. A child safe environment is one in which all participants feel safe to make constructive suggestions and voice concerns at any time. The Child Protection Policy is available for family's reference.

A range of information supporting families, including websites and brochures are also available at the centre

In a safe and supportive environment, services and activities are provided so children:

- feel safe and protected from harm
- help plan activities and make decisions
- are consulted and respected
- have their best interests considered and upheld.

CHILD PROTECTION LEGISLATION INFORMATION

Department of Child Safety, Youth & Women

<https://www.qld.gov.au/child&family/protecting-children>

Child Protection Act 1999

All teaching staff are mandatory reporters.

CODE of CONDUCT

Boondall Staff and Management Committee agree to provide care honestly, ethically and with:

- Diligence and in a professional and courteous manner at all times.
- The best interests of the child being paramount.
- The utmost respect and in partnership with the child and the child's family.
- The utmost respect for authorised officers, and other adults involved in the co-ordination of the kindergarten
- A commitment to quality and continuous improvement in the care provided.
- Respect for cultural, social and religious diversity, differences and perspectives.
- Harassment or abuse (including physical, sexual or verbal, intimidation, humiliation or any behaviour regarded as offensive or degrading) of any child.
- Discrimination, bias, fear or favour.
- In accordance with federal and state government legislation, and Lady Gowrie Qld policies and procedures.

BOONDALL KINDERGARTEN PARENTAL CODE of CONDUCT

Our Kindergarten is committed to engaging with the families of children enrolled in its service in accordance with its values of respect, integrity, safety, collaboration and courage.

We encourage families to actively participate in the education and care programs and aim to engage in constructive and co-operative working relationships with families. We are committed to protecting the safety and wellbeing of the children in our care, their families, staff members, volunteers and all other invitees or visitors to our service. To achieve this we expect that all parents, guardians and family members of children enrolled in our service will conduct themselves in an appropriate manner.

Conduct

In all matters associated with Boondall Kindergarten, parents/guardians must, at all times act in accordance with our values and:

- Comply with the law and Boondall Kindergarten Policies and Procedures (as amended from time to time);
- Comply with the Boondall Kindergarten values when interacting with children and their families, staff members and volunteers. Aggressive, bullying or intimidating behaviour will not be accepted;
- Be respectful of cultural diversity and refrain from harassing, discriminating against or vilifying children, their families, staff members and volunteers on the basis of gender, race, ethnicity, sexuality, religion, age, disability, beliefs or opinions, or background;

- Be respectful of the privacy of children, their families, staff members and volunteers and refrain from taking photographs at our service;
- Comply with the reasonable directions given by staff members to foster a safe and welcoming environment within the services;
- Raise any concerns in accordance with our grievance and complaint management procedure;
- Use our facilities and property and services in an appropriate manner;
- Refrain from smoking at our services and events;
- Not be adversely affected by alcohol or other substances (with the exception of medically prescribed drugs) when attending Lady Gowrie Qld services or events;
- Ensure that all family members and Emergency Contacts associated with a child's enrolment are made aware of this Code and ensure their compliance with this Code.

Consequences of Non-Compliance

Not complying with this Code may have serious consequences. We will endeavour to resolve any matter involving this Code by facilitating discussion between the parties. If the non-compliance is of serious nature or if, in the opinion of our management committee, there is a risk of future non-compliance, we may take any action it considers appropriate in the circumstances. This may include cancelling a child's enrolment at our service.

THE FIRST FEW DAYS

The early days of attendance can be an unsettling time for both child and parent. Here are some hints that may make it easier.

- Talk to your child about the Centre. No matter how young your child may be they will benefit from knowing about what is going to happen.
- Take advantage of the opportunities to orientate yourself and your child to the Centre.
- On the first day allow yourself plenty of time to settle your child and yourself.
- Remember you can ring at any time during the day to find out how your child is going.

How will I know when to say good-bye?

Allow yourself time to share an activity with your child. This will show your child that you are interested in the activities and their day. When your child is settled, then leave. Do not prolong the farewell. When you say you are going to - leave. Always tell your child that you are going and always tell them when you are returning.

Farewell the staff so that they know you are leaving. Teachers are ready to provide the extra support that your child might need at this time. If you leave a crying child you can telephone the Centre later in the day to assure yourself that the child has settled. In most instances you will find that he or she has settled.

What should I know about picking up my child at the end of the day?

Greet your child warmly. To assist children to share their day, staff will provide a summarised account of the main events throughout the day. This gives you a basis to generate discussion with your child about their time at kindy.

Most importantly if you have any concerns about your child's day please talk to your teacher. OPEN COMMUNICATION IS VITAL TO YOUR CHILD'S DEVELOPMENT.

Is your child ready? What can I do to prepare my child for Kindy?

You and your child will be very excited about beginning Kindy. Here are some suggestions to help your child make the transition from home to Kindy a successful one.

- Encourage your child to develop the independence skills of dressing themselves.
- Practice with your child tidying up their toys and bedroom.
- Can your child open lunch boxes and unwrap food?
- Does he / she know which shoe goes on which foot? By allowing your child the time to complete this task on their own, you are promoting a positive self concept.
- Is your child independently toilet trained? By practising this IMPORTANT skill prior to attending Kindy your child will benefit from a smooth transition.
- Health and hygiene are a priority at Kindy. For the benefit of all, please ensure your child can blow their own nose, dispose of tissue, turn on a tap and wash their hands.

REST TIME

Our centre will ensure that the needs for sleep and rest of children are met throughout the program year. The program and service environment will provide opportunities for rest and relaxation across the program day. Where a rest period takes place, staff will ensure that this is a positive experience for children which reflects individual, group and cultural needs. The Service will reflect on the routine of the program throughout the year, adjusting the rest period to be reflective of children and family needs.

BIRTHDAYS

Your child's special day may be celebrated by sharing cakes with the group. Patty cakes are a good option, as they are a reasonable portion for the children.

TOYS

There is a wide assortment of developmentally appropriate toys at the centre. We prefer that the children leave their own toys at home to avoid toys becoming lost or broken. It is especially important that no item containing button batteries or magnets is brought into the centre. The exception is a soft cuddle toy for rest time.

FOOD AND NUTRITION

This Centre upholds the concept of wholesome nutrition based on the five basic food groups. Fruit and vegetables, cheese and biscuits, crackers, yoghurt, sandwiches, etc are promoted as appropriate snack foods and water is readily available.

Parents are advised to consider sending healthy food choices with their child eg. low sugar, no chocolate, low salt. If parents wish their child to have these items, it is recommended that they do so at home where teeth can be cleaned immediately after eating.

REQUIREMENTS FOR KINDERGARTEN

PLEASE NAME ALL ITEMS!!

1. **One named lunch box** which is easy for your child to open themselves, so as to encourage independence. Insulated lunch bags **are not** to be stored in the fridge as they prevent the food from becoming cold in the fridge. **If you wish to use a chiller bag between home and the Centre, please remove your child's lunch / morning tea from the insulated bag before placing in the Centre's fridge. Keep your chiller bag in your locker please.**

The Kindy bag needs to be of a good size to fit lunch boxes, sheets, paintings, etc.

2. **One drinking water bottle** – one bottle approx 500ml – 750ml for your child to drink from during the day. This bottle will be kept in a designated basket that is easily accessible for your child to help themselves to a drink of water throughout the day.

3. **Two sheets**—cut two pieces fabric, bottom sheet →143cm x 65cm and hem all round to a finished size of 139cm x 61cm, and top sheet →144cm x 85cm and hem all round to a finished size of 130cm x 81cm. To finish off the bottom sheet—Cut 1m of strong 2.5cm wide elastic into 4 x 25cm pieces. Affix elastic diagonally across each corner of the bottom sheet, stitching it to the side hem of the sheet 15cm from corner of fabric (as per diagram below to the left. See red dotted line.) Please reinforce the stitching over elastic, as this is an area of the sheets that often pulls away during the year. Final step —fold the four corners under on this bottom sheet onto wrong side of fabric and stitch flat. (please ask teachers for a demonstration)

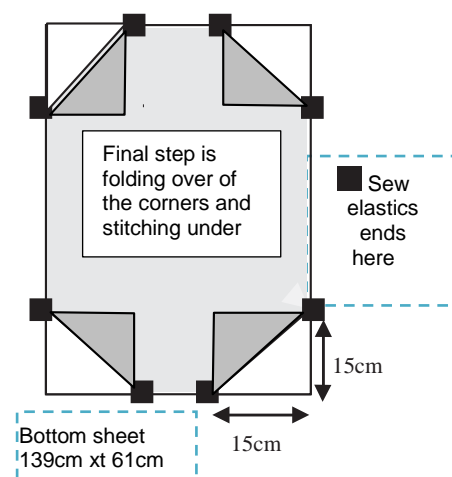

Please write your child's name on top of both sheets so it's visible

4. One sheet bag with drawstring approx. 50cm square.
5. A light blanket for winter is a good idea. **(Same size as sheet)** Some children feel more comfortable with a **small pillow**. Please no bigger than 30cm square. **Please ensure it can fit inside the sheet bag.**
6. One library bag with draw string approx. 50 cm square.

7. **One broad brimmed hat or legionnaires cap. Baseball caps do not provide adequate sun protection.** (As per Sun smart Policy.)
Children will not be allowed to play outdoors if they do not wear a hat.
8. **A spare set of clothes should be placed in a re-useable wet pack/bag,** clearly named and left in the child's bag.

ALL ARTICLES ARE TO BE LABELLED WITH THE CHILD'S NAME.
(Including both sheets, blankets, pillows, hat, shoes, sheet bag)

CLOTHING

Participating in all of the activities of the centre can be a messy business. Exploring and feeling different mediums are important for the development of many skills. Please ensure that your child is able to participate with the group by sending your **child in comfortable play clothes**. We try to use paint and other mediums that do not stain clothing, however, we cannot guarantee that certain materials will not be permanently stained. You may wish to consider setting aside certain articles exclusively for use at the Centre.

LITTERLESS LUNCHES

Our Centre promotes litterless lunches. We ask that children use reusable containers and you refrain from sending pre-packaged foodstuffs (including twist top yoghurts and pre-packaged snacks and biscuits). A compost bin is provided for food scraps. Any litter will be sent home.

INCLUSION POLICY

At our centre, we aim to promote an inclusive anti-bias curriculum which will value the uniqueness of each child acknowledging gender, culture or national origin, religion, family diversity, age, race, ability and indigenous people.

SICK CHILDREN

- Children with contagious illnesses or heavy colds will not be admitted to the Centre.
- Parents must contact the Centre to report contagious illnesses.
- In the event of a child becoming ill in the Centre, the parent will be contacted; therefore it is imperative that the parent ensures the current telephone numbers are with the person-in-charge at all times.
- In the event of a parent or contact not being available, the Director or person-in-charge will take whatever steps are considered to be necessary to ensure the child's well-being.

Children with vomiting, diarrhoea and/or conjunctivitis must have commenced treatment and secretions stopped before a child will be re-admitted to the environment. The last occurrence of vomiting/diarrhoea must be at least 24 hours prior to the child re-attending the environment.

A list of communicable childhood diseases their symptoms and exclusion periods are listed at the end of this information book. If you have any further questions please discuss with the teachers or your doctor.

MEDICATION (AS PER Lady Gowrie Qld POLICY STATEMENT)

1. In the interest of children's safety and wellbeing, medication will only be administered if it is prescribed by a registered medical practitioner, in its original container, bearing the original label with the name of the child to whom the medication is to be administered, and before the expiry or use-by date.
2. Medication is given to treat a condition. One cannot be sure what reaction a child may have to a medication that they have not previously taken. Parents are asked not to bring their child to the Service until **at least 3 doses** of any new medication (they have not taken previously) have been administered.
3. Whenever possible medication will be administered by Parents / Guardians at home.
4. The child's name, parent's signature, name of medication, dose and how the medication is to be stored (eg. Refrigerator) must be entered into the medication book on a daily basis and dated. The signature of the staff member who gives the medicine and the signature of the staff member who witnesses the giving of the medicine are also recorded in the medication book.

Boondall Kindergarten holds an emergency Salbutamol Inhaler & Spacer for emergency asthma first aid and an emergency Adrenaline Auto Injector (Epipen) for emergency anaphylaxis first aid. Authorisation for this is as per the enrolment form.

SUN PROTECTION

We wish to ensure that all children attending our Centre are protected from the harmful effects of the sun throughout the year.

We strongly encourage parents/carers to follow steps as outlined by our Lady Gowrie Qld sun protection policy:

- provide a well-fitting, named hat, broad-brimmed style (brim of 8 – 10 cm), bucket style (with a deep crown and brim size of at least 5 cm) or legionnaire style (not cap) that shades the face, back of neck and ears.
- Provide clothing that covers the shoulders and arms, preferably with a collar, and longer style shorts and skirts to provide protection from the Ultra Violet rays of the sun. Singlet tops do not offer enough protection and are therefore not recommended.
- Apply broad spectrum sunscreen (SPF 30+) to their child each morning upon arrival at the Service if this is not applied prior to arrival.
- Where a child has sensitive skin, provide a personal sunscreen. *This sunscreen must be left with a staff member not in the child's bag or locker.*
- Complete an objection to sunscreen form if relevant for their Family.
- Act as role models by practicing Sun Protection behavior and protecting their own skin.
- Provide a spare T-shirt in the summer months.

ENVIRONMENTAL SUSTAINABILITY

The Early Childhood Australia Code of Ethics stated that we must work with children to help them understand that they are global citizens with shared responsibilities to the environment and humanity. The following Environmental Sustainability practices are in place at Boondall Kindy

- Providing recycling-only bins and encouraging children to recycle
- Reusing packaging, paper and other items for craft activities
- Providing a natural outdoor play environment, including vegetable gardens that children are encouraged to engage with and assist with the care of.
- Providing compost bins for composting leftover food materials.
- Encouraging use of sustainable packaging for food brought from home. (reusable containers)
- Discourage use of plastic wrap and paper bags brought from home.
- Encouraging litterless lunches.
- Solar powered

WEARING SHOES

This Centre recognises the benefit of **barefooted play for children's safety, growth and the development of sensory awareness**. Shoes are a hazard in outdoor play areas. Nerve endings in the feet can sense the variety of textures. Bare feet can grip climbing equipment and promote more effective balance and control, eg. during music sessions or when climbing.

As an additional benefit, noise levels may be reduced indoors when shoes are removed. Children can be encouraged to remove and replace shoes themselves: an independence skill to be fostered.

INJURIES

Parents of an injured child will be contacted immediately. An "incident" report is kept at the Centre to comply with the Workplace Health and Safety Regulations.

IMMUNISATION IS VITAL

We strongly recommend that children should be immunised against diphtheria, whooping cough, tetanus, poliomyelitis, chicken pox, measles, mumps and rubella. Immunisation is our protection against epidemics of highly infectious childhood diseases. The diseases, though rare in Queensland in recent times, are still in existence and if the community level of protection is not kept high, epidemics will occur in the future.

Parents of non-immunised children will be asked to sign a "Conscientious Objection to Immunisation" form, thus agreeing to the removal of their child should an outbreak of a preventable disease occur. For further information, please refer to Lady Gowrie Qld policy.

FIRE DRILLS, EMERGENCY & EVACUATION PROCEDURES

We practice **fire evacuation drills and lock downs** so staff and children are familiar with the procedure. Evacuation procedures are displayed in the room. If the fire bell is ringing, please do not enter the premises. In the event of a lock down, procedures are in place to ensure safety of staff and children. (Procedures as per Lady Gowrie Qld Environmental Hazards Policy)

HEALTH, HYGIENE & SAFETY

As per regulations, compliance with Health, Hygiene & Safety policies are followed in the Centre, as outlined by current Workplace Health & Safety Standards. Policies include:

- Risk and safety assessment;
- Use of disposable gloves;
- Hand washing;
- Sunscreen application.

INSURANCE

Boondall Kindergarten holds insurance with Guild Insurance Ltd. Policy No. P00248567

SMOKING

Smoking is not permitted at any Early Childhood Education and Care facilities, and for five metres beyond their boundaries.

STUDENT PLACEMENT/WORK EXPERIENCE

This Centre recognises the importance of student placements as being consistent with the long term training of staff in the provision of quality education and care for children. Students are supervised both by Centre staff and by University/TAFE Staff. Please note at no time will a student or volunteer be left alone with the children. All students must hold a blue card.

FEES

The Kindergarten is a non-profit organisation and receives funding from the State Government QKFS (Queensland Kindergarten Funding Scheme). This funding contributes to some of the costs associated with running the Kindergarten but does not cover all costs. Costs include staff wages, rates, insurance, electricity, telephone, cleaning, maintenance, educational aids, crafts materials, Lady Gowrie Qld affiliation fees, staff training, show/presentations etc. Kindergarten fees provide the additional funds to cover these costs. Kindergarten fees are set annually as part of the Kindergarten budget process and approved at a management committee meeting. It is very important that fees are paid on time to ensure the efficient running to the Kindergarten.

As the QKFS per child funding is a major contribution to cover costs for enrolled children if you DO NOT nominate our centre for QKFS, you will incur additional fees to offset this lack of funding.

FEES STRUCTURE

Fees for 2022 include:

Fee	Details	Per year
Enrolment Fee **		
Administration Fee	Non-Refundable	\$139
Membership Fee	Non-Refundable	\$11
Roster Bond	Refundable if roster requirements met	<u>\$100</u>
		<u>\$250</u>
Term Fees	\$920 per term <i>\$20 discount applies if payment received in full by the due date.</i>	\$3,680

*** Enrolment Fee payable to secure enrolment. Pro-rata fees may apply on administration & roster bond for mid-year commencement.*

Fees are payable for enrolled children whether they attend Kindergarten or not. Illness, exclusion due to an infection and/or vaccine preventable disease and public holidays are not exempt from payment.

The Kindergarten is a non-profit organisation and we have limited enrolment numbers. The withdrawal of a child from the Kindergarten greatly affects the financial position of the Kindergarten.

To minimise the loss of income to the Kindergarten we request that four weeks notice in writing (or two weeks fees paid in lieu) of intention to withdraw a child from Kindergarten be provided. **As it is too disruptive to the Kindergarten to replace a child during Term 4 any advice of withdrawal received after Term 3 finishes will incur the full Term 4 fees.** In the event of a child's non-attendance for 2 weeks and no notice being received, the child's enrolment will be automatically suspended. Please advise in advance when going on holidays or notify the Director if your child cannot attend due to illness.

FEE DUE DATE & PAYMENT OPTIONS

Fees are due in full by the due date. A term invoice will be emailed at least 2 weeks prior to the due date. Payment can be made by direct debit via internet banking or at any Bank of Queensland (BOQ) branch. Bank account details will be recorded on the term invoice. Please use your child's full name as reference.

No cash/cheque/money order payments please!

You must pay by the due date to receive the \$20 discount. Due dates for 2022 are:

Term 1 – Friday 11th February 2022

Term 2 – Friday 22nd April 2022

Term 3 – Friday 15th July 2022

Term 4 – Friday 7th October 2022

To assist families to pay fees they may elect to enter into a fee payment plan to make weekly, fortnightly or monthly payments. This is done via completing an Ezi Debit payment plan form which is available from the Finance Administrator. Families using Ezi debit payment plans will not be entitled to the \$20 discount and all fee payments must be completed by week 6 of Term 4.

To make alternative payment arrangements, you must speak to the Finance Administrator before the invoice due date.

FEES IN ARREARS/ LATE FEE

Non-payment of fees by the due date or in accordance with an approved payment plan may result in your child(ren)'s enrolment being cancelled.

If fees are outstanding upon the departure of the child(ren) from the Kindergarten, the outstanding debt remains payable to the Kindergarten.

The Kindergarten reserves the right to take action to recover debts owing to us. The cost of recovering any debts owed (including legal fees) will be added to the outstanding debt owed and will become a debt payable to the Kindergarten by the parent/guardian.

Staff must perform many non-contact tasks after Kindergarten closing times and must be able to leave work on time. For this reason it is critical that children are collected on time. Where a child is not collected by the Kindergarten closing time a late collect fee may be imposed.

QKFS KINDY PLUS SUPPORT

Families of eligible-aged children may be eligible to access QKFS Plus Kindy Support. This support is available to children who meet one of the following criteria:

- a current Australian Government Health Care Card (HCC), Pensioner Concession Card or Department of Veterans' Affairs Gold Card or White Card (or formal communication, such as a letter, from the relevant agency stating the intent to issue a HCC)
- The child is Aboriginal and/or Torres Strait Islander and the family chooses to identify them as such on their enrolment form
- The family has 3 or more children, of the same age, enrolled in the same year

If you believe you are eligible for QKFS Plus Kindy support, please ensure you provide relevant details on enrolment (or as soon as possible in the event that your circumstances change during the year). Please speak to the Finance Administrator if you require more information on this support.

QKFS Plus Kindy Support payments will be allocated to Term Fees when received. If you pay full fees and later QKFS Plus Kindy Support payments are received the payment will be applied to your account and a refund issued (if applicable). In the event that you cease to be eligible for QKFS Kindy Plus Support you will be liable to pay Term fees due.

ROSTER BOND

At the end of Term 4 families are eligible for a refund of roster bond paid on enrolment. To be eligible for a refund, families must have completed roster requirements. For a full year enrolment, this includes contribution to:

- Maintenance of education facilities (1 working bee)
- Decision making processes of the centre (attend 2 meetings)
- The day to day education of the children (4 parent rosters)

Enrolments commencing mid-year will be advised of roster requirements.

MEMBERSHIP

Each family is required to pay a non-refundable membership fee on enrolment. You will then be a financial member of the Association allowing you to vote at Annual and Special General Meetings.

FAMILY INVOLVEMENT / VOLUNTEERS

This Centre recognises the important role played by parents in the education of their children and values parent participation and involvement on a variety of levels eg. sharing skills and interests in the educational curriculum, attending parent meetings and social functions and becoming involved at committee management level.

We appreciate any relevant information you can share about your child with the teacher. This enables the staff to understand your child's and family's needs better.

Rostered times ensure that there are a comfortable number of adults in the Centre at any one time. Any help you can give us is always very much appreciated. By law, any parent or guardian who has received a negative notice of a blue card or has a prior conviction must not volunteer to help with supervision or hold a committee position.

PARENT RESPONSIBILITIES

It is the Parent's responsibility to:

- notify the children's teacher regarding changes in information recorded about a child. This includes current information as to emergency contact numbers/court orders/changes in family arrangements. These changes may impact on the child's behaviour or emergency contact action,
- comply with relevant health & hygiene policies of the centre,
- sign all enrolment forms, including the enrolment agreement (a condition of enrolment) and return these to the centre.
- As a community kindergarten, feedback is vital. From time to time you may be asked to complete a survey about a particular issue. You are encouraged to participate in these surveys.

PARENT/TEACHER COMMUNICATION

Parents are encouraged to speak with their child's teacher about their child's progress, or any concerns they may have. Open communication between parents and staff facilitates positive home/kindergarten relationships based on trust and positive cooperation.

Where discussion is needed it is important to make an appointment to speak with the teacher outside of session times rather than to take the teacher's attention away from the children. This also gives the teacher the opportunity to refer to developmental records and observations while discussing any concerns. Roster days are also an ideal time to discuss important matters.

Where a parent has any concern relating to the curriculum, the waiting list or roll, this Association advocates that the parent make direct contact with the teacher responsible for that group of children.

Where a parent has any query relating to the payment of fees or any matter relating to committee management or administration, this Association advocates discussion with the appropriate committee member or administrator.

If the parent remains unsatisfied, or feels unable to approach the teacher further, they should contact first the Director, and then, if necessary, the Boondall Kindergarten Association President.

If the parent is still not satisfied, a complaint should be made in writing to the Boondall Kindergarten Association Management Committee

If the matter cannot be resolved, the Lady Gowrie Qld Early Childhood Education & Care Consultant, Tracy Joyce may be asked to assist - 0448 743 595 or tracy.joyce@ladygowrie.com.au.

Finally, the Office of Early Childhood Education & Care may be contacted for further assistance. The Office of Early Childhood Education & Care can be contacted on 3634 0532 (Nundah Office).

WAITING LIST

A child wishing to attend the Kindergarten may have his/her name placed on the waiting list on or after the day on which he/she was born. A non-refundable fee of \$10.00 is payable upon enrolment.

Children are offered a place strictly in accordance with their position on the waiting list.

PARENT LENDING LIBRARY

There is a parent resource library for borrowing. These books may be borrowed for two weeks. Please ensure that the book is signed out and in again.

ENROLMENT/ FEE PAYMENT AGREEMENT

BOONDALL KINDERGARTEN ASSOCIATION POLICIES AND PROCEDURES

In consideration of the enrolment of my child in the Boondall Kindergarten, I / we do agree that:

1. I / We have visited the service and discussed with the Nominated Supervisor / Teacher the enrolment of my / our child. I / We understand the importance of family cooperation and agree to participate where possible in the activities of the Kindergarten.
2. I / We agree to abide by and be bound by the constitution / rules, by-laws, regulations and policies of the Association (Copies are available from the Kindergarten).
3. I / We understand that if my / our child is enrolled in a kindergarten program at this service, and is of the eligible age group, it is my / our responsibility to inform the service if my / our child is enrolled in any other early childhood education facility, whether it be a Gowrie service or not.
4. I / We understand that the Queensland Government provides funding to a kindergarten service for my / our child to attend 15 hours of kindergarten per week for 40 weeks per year. Receipt of this funding by the service ensures that my / our out-of-pocket fee expenses are kept as low as possible, and therefore, the registered kindergarten service that my / our child attends will be the recipient of such funding.
5. I / We understand that it is my / our responsibility to ensure that no other early childhood education facility, where my / our is enrolled, claims kindergarten funding for my / our child as the funding required to support my / our child's position in this kindergarten service will be claimed by this service. Therefore no other service will be entitled to make a claim for kindergarten funding.

N.B Your signed copy of this agreement is kept in your child's file at the centre. Please re-familiarise yourself with this agreement.

Fees

1. I / we are responsible and liable to pay all fees and charges:
 - whilst my / our child is attending the service,
 - by the due date and in accordance with the service's fee schedule,
 - where my / our child is not collected by the service's closing time and I / we incur a late fee,
 - when my / our child is absent from the service for whatever reason, including (but not limited to) public holidays, pupil free days, holidays, illness or exclusion due to an infection and / or vaccine preventable disease or illness,
 - if my / our child receives medical treatment from a registered medical practitioner, hospital and / or ambulance service and / or transportation by the ambulance service, in the event of an emergency,
 - for the whole or part of the minimum notice period, where I / we cancel my / our child's enrolment without giving the service the minimum period of time required as notice.
2. If I / we do not pay the fees and charges by the due date, my / our child's enrolment may be suspended or cancelled.
3. If we are concerned I / we will not be able to pay the fees owing by the due date I / we will speak to the service director as soon as possible.
4. I / we understand that State and / or Commonwealth funding arrangements may change which may result in fees subsidies no longer being available. I / we understand that where Government fees subsidies are no longer available I / we will be required to pay the full fees.
5. I / we acknowledge that unpaid fees constitutes a debt owing to the service, regardless of whether I/we remove my child(ren) from the service or whether my child(ren)'s place at the service is suspended or cancelled. I/we acknowledge that if legal action is taken to recover a debt owed, the cost of recovering any debt owed will be added to the debt owed and will become payable to the service by me/us.
6. Lady Gowrie Qld's Fee policies are available on the Lady Gowrie Qld website.

Queensland Kindergarten Funding Scheme

7. If my / our child is of the eligible age (turning 4 by 30 June in the year they attend kindergarten), I / we will:
 - a) inform the service if I / we have a valid concession card.
 - b) present and provide the details of the concession card to enable the service to claim any subsidy I / we may be entitled to. If my / our card is not presented before commencing at the service, I / we am / are aware that full – fees will be charged.
 - c) notify the service if the status for my / our concession card changes or expires. I / we am / are aware if I / we do not do this full fees will be charged.
 - d) provide a copy of my / our concession card if I / we am / are issue with a new card whilst my / our child is enrolled.

8. Lady Gowrie Qld will claim funding (QKFS) from the Queensland Government for my child where my / our child is of the target age group and is enrolled in a kindergarten program at this service. I understand that if I do not nominate this service to receive QKFS, additional fees will be incurred.

Attendance

9. I / we will promptly notify the service if my / our child will be absent and the reason for the absence.
10. I / we will ensure that my / our child is delivered to and collected from the service by an authorised, responsible person and my / our child is:
 - a) handed over to a member of the service staff, and
 - b) signed in on delivery to, and signed out on collection from, the service.

Suncare and health

11. I / we have read a copy of and understand the service's sun care and protection procedure, and exclusion due to illness procedure and will comply with it.
12. I / we will notify the service in the event of my / our child having an infectious illness.

Child protection

13. I / we understand that all Boondall Kindergarten staff and personnel (including committee members of an affiliated kindergarten) will make a report to the appropriate authorities if they suspect that any child at the service has experienced or is experiencing physical, sexual or emotional harm or neglect as a result of parent / guardian action or inaction.

Correct and up-to-date information

14. I / we confirm that the information provided in this enrolment booklet is true and correct.
15. I / we will immediately inform the service, in writing, if there is any change to the information I / we have provided, including the emergency contact listed.

Copies of the Kindergarten Association's insurance policy and schedule of current covers are available for inspection at the Kindergarten.

MANAGEMENT COMMITTEE

The management committee is formed by parents of children currently attending or interested members of the community. There are usually 14 positions on the management committee. The management committee meets once a month and are responsible for:

- general management and financial matters of the centre.
- following the rules of the association/constitution lodged with the Department of Fair Trading.
- Ensuring the centre is meeting Lady Gowrie Qld affiliation standards so the centre continues to receive QKPS funding.
- the employment of all necessary staff and compliance with the provisions of any awards or other industrial requirements.
- Legislative requirements affecting the centre including the Child Care Act (2002), the Child Care Regulations (2003) and other legislation such as Child Protection and Workplace, Health & Safety legislation.
- building and playgrounds.
- Promoting the centre within the community

At the Annual General Meeting, the Association elects an executive management committee from its members (consisting of a President, Treasurer, Secretary and Vice President) who are then in charge of the general management and financing of the Centre and have voting rights at monthly meetings. Members of the executive committee must hold a blue card. Skills that would benefit the committee as a whole (in any position) could include:

- Accounting
- Information Technology (computer)
- Justice of the Peace
- Human Resources
- Any previous experience on a management committee would be very helpful.

We'd love to hear from you!

JOB DESCRIPTIONS

Executive Positions

President

- Chair the monthly meeting.
- Delegates responsibilities to other parents and committee members.
- Heads the executive committee.
- Liaises with staff and Boondall Kindergarten Association.

Secretary (often a shared position)

- Prepares a written agenda for monthly meeting.
- Takes minutes of monthly meeting.
- Types reports.
- Tends to inwards and outwards correspondence.

Vice President/Treasurer

- Takes over in the absence of the President.
- Works closely with the President.
- Attends monthly meeting.
- Presents financial report to monthly meeting.
- Oversees administrator.
- Attends monthly meeting.

Non-Executive Positions

Workplace Health & Safety Officer

- Attends monthly meeting.
- Reports to monthly meeting re: immediate needs for maintenance.
- Organises outside help or quotes for maintenance work.
- Ensures the Kindergarten complies with current WH&S guidelines.

Working Bee Officer

- Organizes and supervises three (3) Working Bees.
- Provides a report to the committee after each Working Bee.

Marketing Officer

- Contacts media re: special events.
- Co-ordinates a monthly newsletter.
- Attends monthly meeting.

Grants Application Officer (a shared position)

- Works on submissions for grants. eg the gaming fund.

***NB The roles of Secretary, Grants Application officer and Marketing Officer are best shared by two parents (one from each of the groups).**

Technology Officer

- updates web page with photos & newsletters

Social Committee / Einbunpin Sub-Committee

The Social Committee is made up of 4 or more interested parents whose sole aim is to organise some social functions throughout the year. The sole purpose of the Einbunpin Sub Committee is to coordinate our stall for the Einbunpin Festival held at the end of July. (A decision early in the year will be made regarding participation in the annual festival at Sandgate)

COMMUNICABLE CHILDHOOD DISEASES

Chicken Pox

Symptoms include: Fever, runny nose, cough, fatigue and general rash.

Exclusion period: 2 weeks or until all sores have gone and child feels well.

Incubation period: 10-21 days.

Measles

Symptoms include: Fever, tiredness, cough, runny noses and inflamed eyes which may result in avoidance of light.

Exclusion period: Until 4 days after rash appears.

Incubation period: About 10 days.

German Measles (Rubella)

Symptoms include: Fever and a general body rash and swollen glands.

Exclusion period: Until fully recovered.

Incubation period: About 14-21 days.

Mumps

Symptoms include: Tender swelling chiefly of parotid glands in front of and below ear.
Headache, moderate fever, pain on swallowing

Exclusion period: Until swelling goes down.

Incubation period: About 14-21 days

Streptococcal Infections

Symptoms include: Fever, sore throat and oozing and redness of the tonsils and the upper part of throat.

Exclusion period: Until appropriate medical treatment given for at least 24 hours.

Covid 19

Symptoms include: Fever, cough, tiredness, loss of taste or smell

Exclusion period: At least 10 days aer the onset of illness and until they have not had any symptoms for 3 days

Incubation period: On average about 5-6 days

COMMUNICABLE CHILDHOOD DISEASES (CONT'D)

Whooping Cough

Symptoms include: Early symptoms resemble typical common cold. Cough worsens and may become violent and paroxysmal. Vomiting may be caused by coughing or nervous system irritation; cough may linger for up to 3 months.

Exclusion period: 5 to 7 days after starting antibiotic treatment.

Incubation period: About 5-21 days (usually within 10 days).

Ringworm

Symptoms include: Spreading ring-shaped lesion. The outside is usually reddish often containing fluid, but may also be dry and scaly or moist and crusted. The centre of the patch may appear to be healing.

Exclusion period: Exclusion from the Centre until appropriate treatment has commenced. Lesions must be covered.

Incubation period: Unknown.

Scabies

Symptoms include: Intense itching often on forearms, chest and neck.

Exclusion period: Exclusion from the Centre until treatment has commenced killing mites and eggs.

Head Lice

Symptoms include: Itching of head behind ears and above neck, grey-white specks (eggs) glues to hair within 6 mm from scalp. Lice are less than 3 mm long, translucent or tan in colour and move.

Exclusion period: Exclusion from the Centre until after first treatment and clear.

Conjunctivitis

Symptoms include: A scratchy feeling in one or both eyes and redness in whites of the eyes. A discharge may be present causing eyelids to stick together first thing in the morning.

Exclusion period: Until clear.

School Sores

Symptoms include: A flat, yellow, crusty or moist patch in the skin.

Exclusion period: Exclusion from the Centre until appropriate treatment has commenced and sores are covered.

Incubation period: 1-3 days.



We look forward to welcoming you to Boondall Kindergarten and hope you enjoy your time with us.